

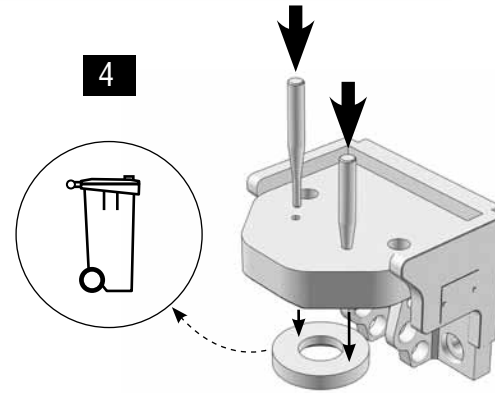

Führungsbuchsen kompl. 5085 T  
Guide bushes compl. 5085 T

Bestellnummer / Order number: 14 996 641

## Einbauanweisung/Mounting instruction

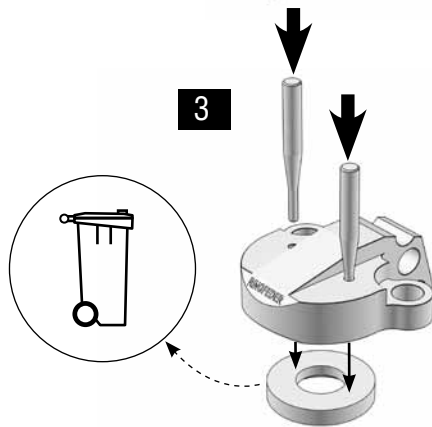
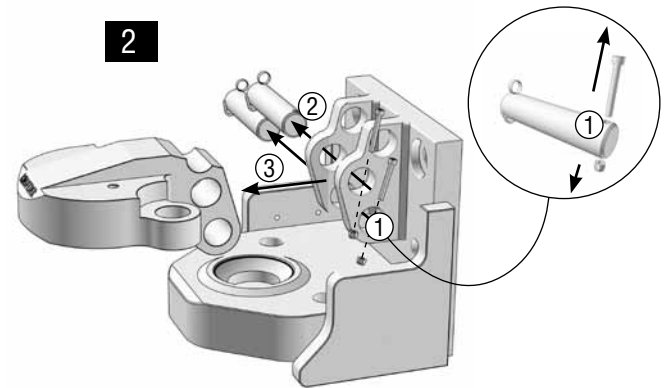
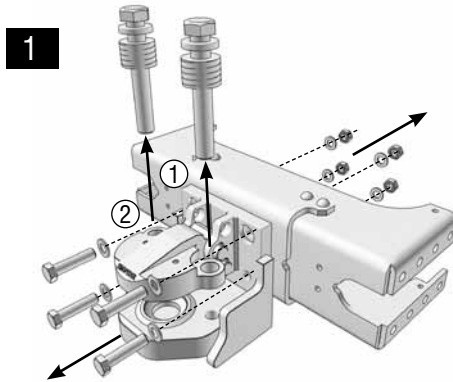



Führungsbuchsen kompl. 5085 T  
*Guide bushes compl. 5085 T*

Bestellnummer / Order number: 14 996 641

## Einbauanweisung/Mounting instruction



5

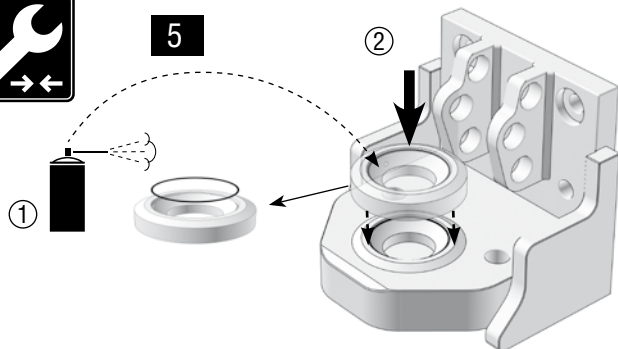

7

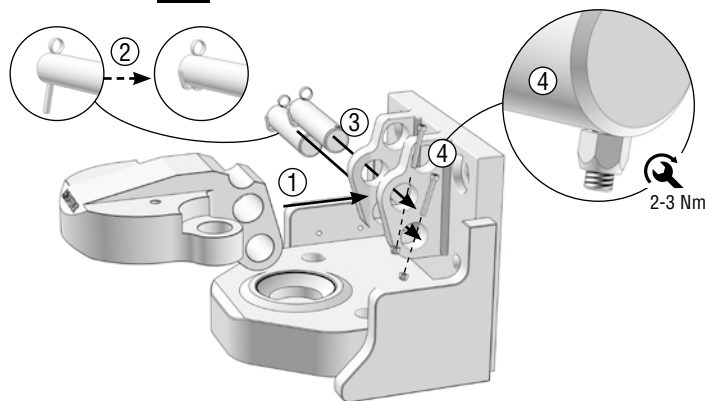

6

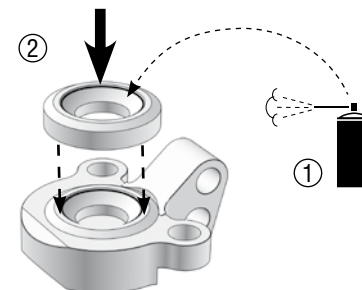

8

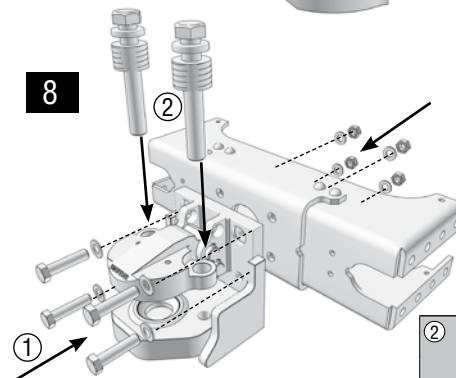

②	Nm	mm
	625-650	46

①				Nm	mm
	M20 x 100 DIN 933 ( $\geq 8.8$ )	$\geq 200$ HV	$\geq 8$	380-420	30





Verschlusschrauben kompl. 5085 T  
Locking screws compl. 5085 T

Bestellnummer / Order number: 14 996 533

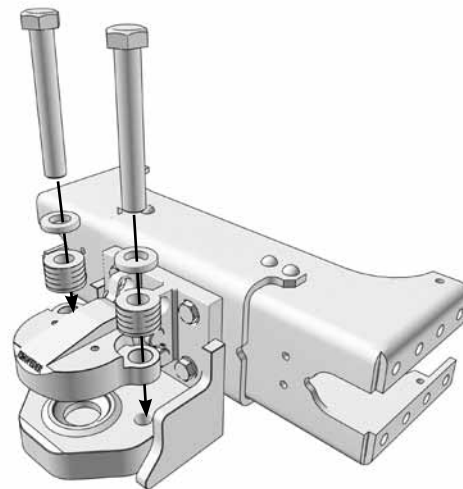
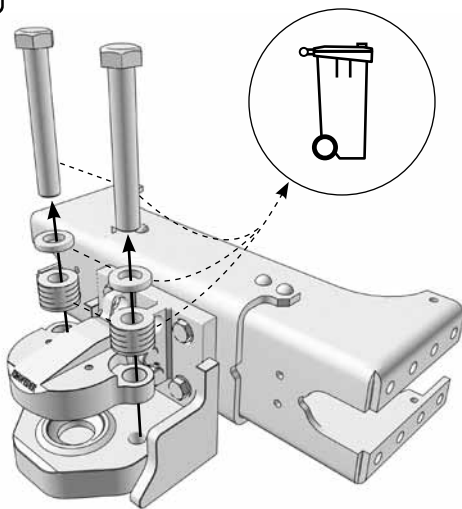
## Einbauanweisung/Mounting instruction



 Nm	 mm
625-650	46



Sicherungsbolzen kompl. 5085 T  
Security bolts compl. 5085 T

Bestellnummer / Order number: 14 996 570

## Einbauanweisung/Mounting instruction

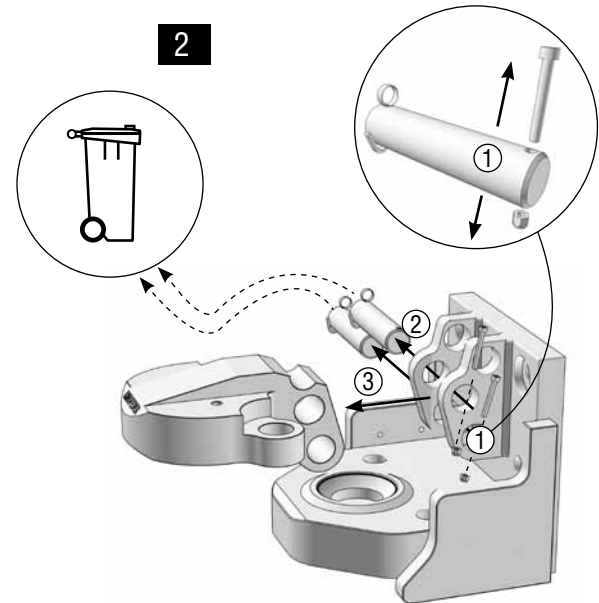
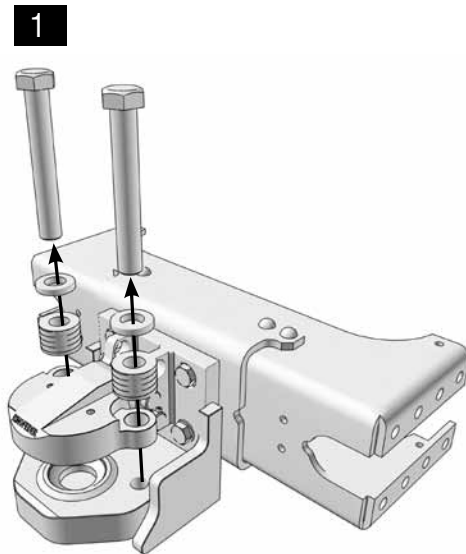



Sicherungsbolzen kompl. 5085 T  
Security bolts compl. 5085 T

Bestellnummer / Order number: 14 996 570

## Einbauanweisung/Mounting instruction



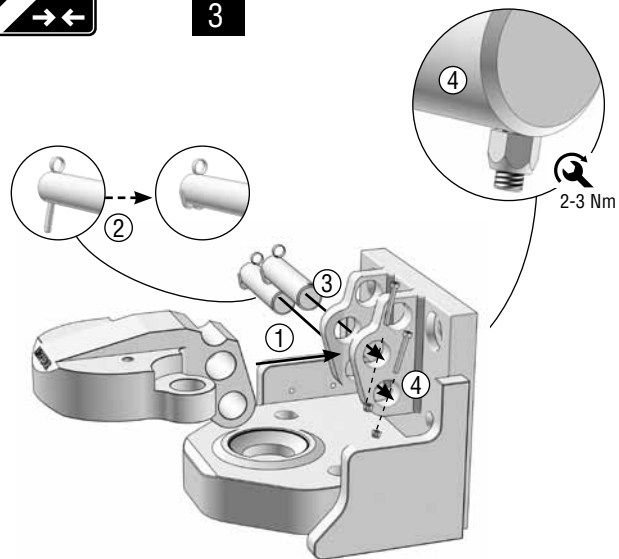

3

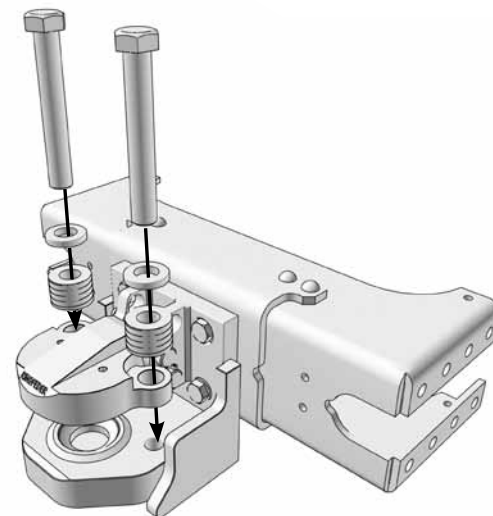

4



 Nm	 mm
625-650	46





**Kugel kompl. 5085 T**  
**Ball compl. 5085 T**

Bestellnummer / Order number: 14 996 531

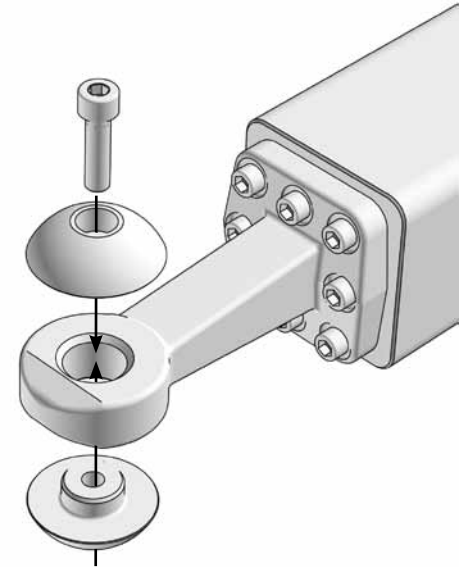
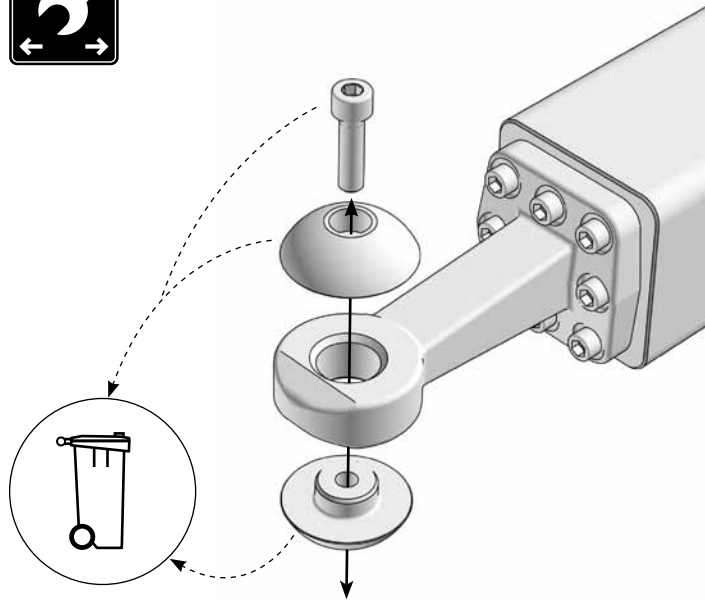
## Einbauanweisung/Mounting instruction



 Nm	 mm
380-420	17





Zugöse kompl. 5085 T  
Drawbar eye compl. 5085 T

Bestellnummer / Order number: 14 996 540

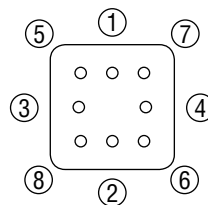
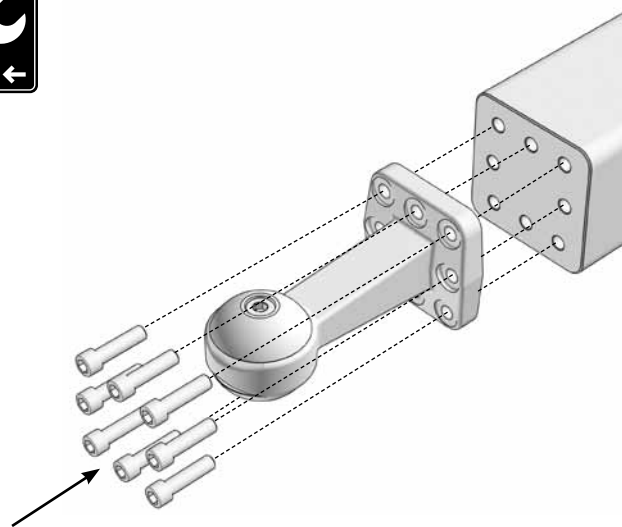
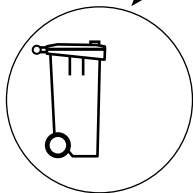
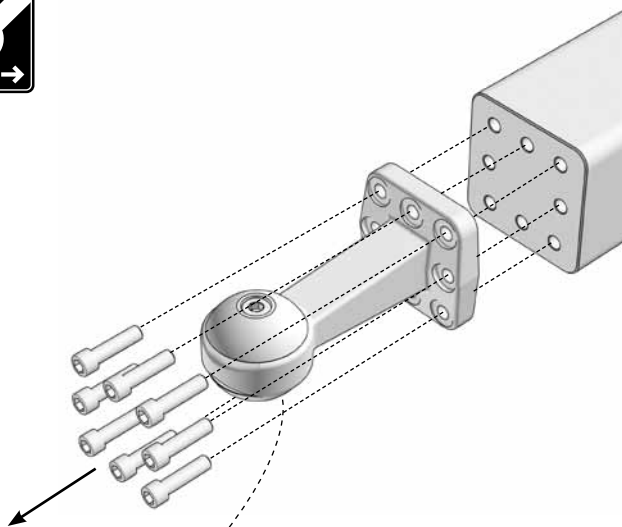
## Einbauanweisung/Mounting instruction



	 Nm	 mm
M16 x 50 DIN 912 (10.9)	250-280	14







Schraubensatz für Zugöse 5085 T  
Fastening screws for drawbar eye 5085 T

Bestellnummer / Order number: 14 996 641

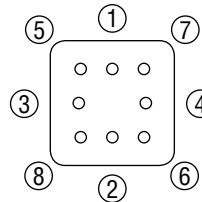
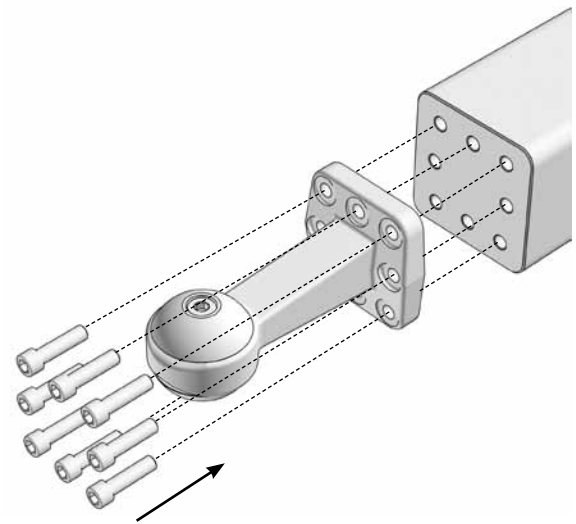
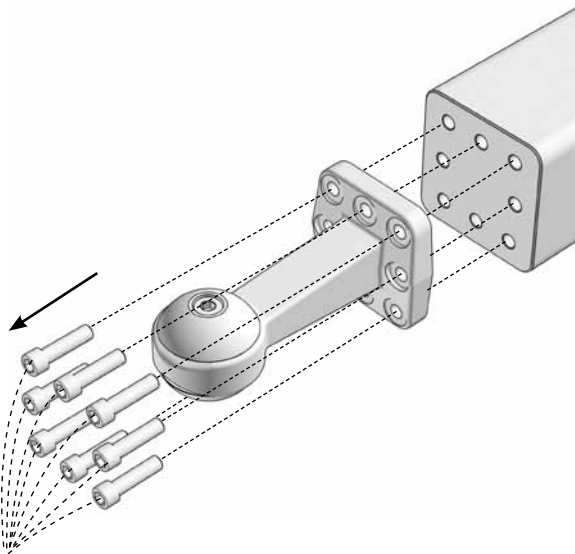

## Einbauanweisung/Mounting instruction



	 Nm	 mm
M16 x 50 DIN 912 (10.9)	250-280	14

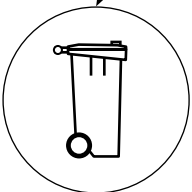



**Schraubensatz für Kupplung 5085 T**  
**Fastening screws for coupling 5085 T**

Bestellnummer / Order number: 14 996 551

## Einbauanweisung/Mounting instruction

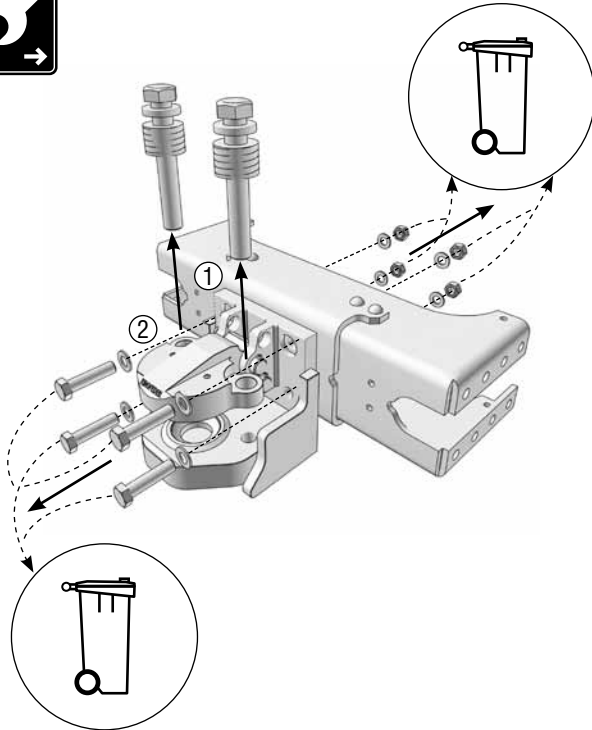

②	Nm	mm
	625-650	46

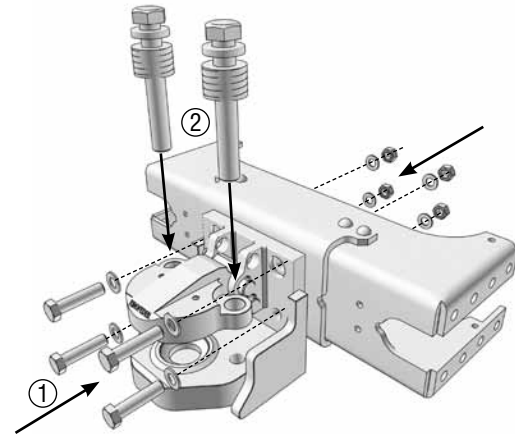

①				Nm	mm
	M20 x 100 DIN 933 (≥ 8.8)	≥ 200 HV	≥ 8	380-420	30